

Mounting and Removal Instructions for

STÜWE® Flange Coupling FK HYD

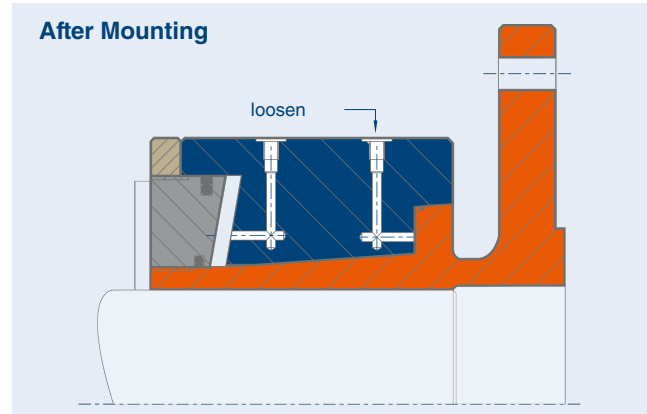
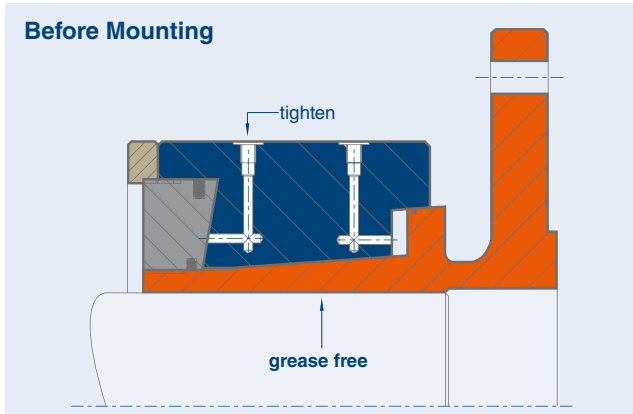

Mounting

The STÜWE® flange couplings type FKHYD are supplied ready to be mounted and with hydraulic oil in the pressure chamber.

1. Shaft and hub must be absolutely free of grease in the fit area. Full torque transmission is absolutely dependent on this measure. Do not use contaminated cleaning solvents and unclean rags.
2. Push the flange onto to the shaft.
3. Remove screw plugs from the "Spannen" (Tighten) and "Entspannen" (Loosen) connections. Collect any oil leakage.
4. Connect pressure line to connection marked "Spannen" (Tighten).
5. Tighten the shrink disc by applying hydraulic pressure. The correct tightening force is reached as soon as the end faces of the outer and inner ring are aligned (visually observed to be flush). **Maximum allowable hydraulic pressure is 450 bar!**
6. When pressurising the flange it will initially tilt with an in and out radial motion until the fit clearances are bridged. Thereafter a true seat between bore and shaft is achieved and any tilting eliminated. The correct tightening force requirement is achieved as soon as the outer and inner rings are aligned (visually observed to be flush). The max. allowable hydraulic pressure is stamped on the Flange Coupling.
7. Tighten the counter nut by hand against the outer ring.
8. Release the hydraulic pressure. The safety nut will then be tightly compressed against the outer ring due to the stored energy.
9. Replace the screw plugs to retain the hydraulic oil in flange coupling.

Dismounting

1. Remove screw plugs from the "Spannen" (Tighten) and "Entspannen" (Loosen) connections. Collect any oil leakage.
2. Connect the pressure line to the connection marked "Spannen" (Tighten).
3. Increase the hydraulic pressure until the safety nut can be loosened by hand (**max.450 bar!**). Continue loosening the safety nut.



Make sure that a minimum of two turns remain connected when loosening the ring nut. Otherwise the nut might fall off! This could be dangerous and result in injury.

4. Release the hydraulic pressure and connect the pump to the "Entspannen" (Loosen) connection.
5. Increasing the oil pressure (max. 450 bar!) will initiate the release of the connection. **As soon as the outer ring starts sliding towards the ring nut reduce the oil pressure immediately to max. 150 bar.** When the outer ring reaches the support ring the oil pressure will automatically increase. **At this point fully release the oil pressure. Make sure the oil pressure does not exceed 180 bar.**
6. The connection is loose now. Collect oil leakage coming out of the "Spannen" (Tighten) connection.
7. Leave all hydraulic oil within the shrink disc and replace the "Spannen" (Tighten) and "Entspannen" (Loosen) screw plugs so that the flange coupling is oil tight.
8. Remove the flange from the shaft. Prior to removal clean off any rust from the shaft in the immediate vicinity of the flange.